

Technical Data Sheet – MagFlex®

Product Features

With the flexible MagFlex® formwork system, any curves from a radius of 35 cm can be formed. Due to its individual components, the formwork can be easily assembled and set up by one person. Special holding magnets with MagFly® technology ensure exact positioning and a secure hold.

Product Features

- ::: The individual components allow easy handling, effort-saving transport and space-saving storage.
- ::: Very fast realisation of special formwork structures
- ::: Easy setting and aligning due to spring eccentric components and robust fixing mechanism
- ::: Very economical due to speed, reusability and considerable reduction of waste compared to conventional formwork

Areas of Application

Forming of any curves possible from a radius of 35cm

Technical Data

Article number	8109173	8109174
Name	MagFlex® 1000*	MagFlex® 1000*
Magnets	15	15
Adhesive force/system [N]	11.000	11.000
L [mm]	6.000	6.000
W [mm]	425	425
H [mm]	260	300

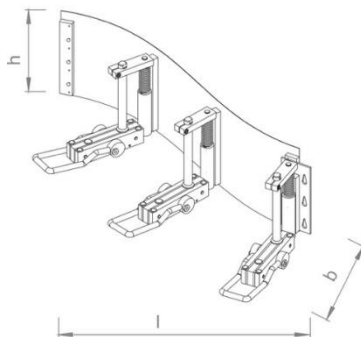

Artical Data & Form of Delivery

MagFlex® is supplied as a complete system and consists of standard of two 3 m long spring steel elements with 30cm formwork height, 15 fixing magnets with the patented MagFly® system and an adhesive force of 10,000 N each, as well as a connecting element to join the spring steel sheets together. Other heights and lengths are available on request.

The holding magnets are not firmly connected to the formwork. They can be removed from the holders for transport and storage.

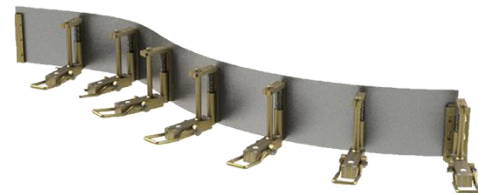

The information in this data sheet was provided with care based on our experience and the respective known state of science and technology but is non-binding. They are to be adapted to the respective building object, intended use and the special local stresses. Provided that this is the case, we ask you to understand that we limit our liability for the information given in this data sheet and accept no liability in the event of intent, gross negligence or infringement of the instructions. In any case, the recognised rules of technology must be observed.

Edition 05/19 - This data sheet has been technically revised. Previous editions are invalid. If a new edition has been technically revised, this edition loses its validity. Please check whether you are in possession of the current edition